

Figure 14. Guide to the interpretation of CEC values for sand, loam and clay soils

What practices change CEC?

CEC is closely linked to the level of organic carbon in the soil, so changes in CEC over time should reflect changes in organic carbon. However, some soils that have very high clay content—such as vertosols (black cracking clays)—will have a naturally high CEC due to the clay minerals.

For most soils the best method for increasing CEC is to increase the amount of organic carbon in the soil by adding organic matter.

Increasing soil pH also increases the CEC of some acid soils.

Individual cations can be applied to correct any imbalances. For example, calcium can be applied as lime to raise soil pH, or as gypsum to counteract sodicity when there is a lot of exchangeable sodium present. If magnesium is required it is usually applied as a top dressing of dolomite or magnesium oxide. Potassium can be applied in blended fertilisers in conjunction with nitrogen and phosphorus, but can also be added as potassium nitrate, potassium chloride or potassium sulphate. Other cations such as sodium, aluminium, and hydrogen are not essential for plant growth and, if present in excess, cause toxicities.

Splitting the application of fertilisers to soils with low CEC will reduce leaching of added nutrients below the root zone.

Sodium saturation

What is sodium saturation?

Sodium saturation measures the amount of sodium as a percentage of CEC. The units may be written as sodium percentage (Na%) or exchangeable sodium percentage (ESP), but they are the same measure.

Soils with a high proportion of exchangeable sodium (greater than 5% of the CEC) are referred to as sodic soils. (For more information see ‘Sodicity’ on p. 18).

Sodicity is different from salinity, although these conditions can occur together. Salinity refers to the amount of salts present in the soil and is often measured by electrical conductivity (EC). The greater the salt concentration, the higher the EC.

Why is sodium saturation important?

Sodium saturation is important in determining the physical properties of a soil. Soils with high sodium saturation tend to lose aggregation and disperse. As they lose structure they become less permeable to water and surface crusts may develop. This results in poor conditions for root growth. Soils tend to disperse when Na% is greater than 5% of the CEC.

How is sodium saturation measured?

Sodium saturation is included in soil tests from most reputable laboratories. It is calculated as the amount of sodium as a proportion of the CEC.

The Emerson dispersion test (see p. 6) is linked with sodium saturation in that it identifies a dispersing soil.

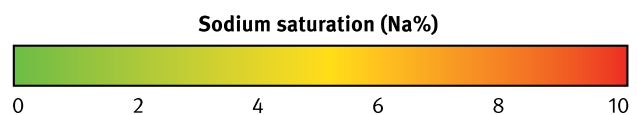

Figure 15. Guide to the interpretation of sodium saturation values for soils

What practices change sodium saturation?

Sodic soils with a high Na% can be corrected by applying calcium, normally as gypsum. Calcium ions displace the sodium ions attached to soil particles. In acid-sodic soils, lime can be applied, which will increase the soil pH as well as increase the calcium content of the soil. However, in soils with a neutral or high soil pH, gypsum is preferred because it will increase the calcium content of the soil without further increasing soil pH.

Once the Na% is corrected it is important to maintain a low sodium content by reducing sodium inputs from saline irrigation water. It is also important to maintain calcium levels in the soil so that they are not displaced by additional sodium. Poor quality irrigation water, high in sodium, can cause sodium to displace calcium from the clay particles, resulting in sodicity.

Increasing SOC can help reduce some of the dispersive effects caused by high Na%. Practices such as reduced tillage and mulching of green manure crops can increase SOC without increasing sodium. In sodic soils with a high Na%, be careful that added organic amendments or biological products are not high in sodium. If the sodium content of the amendment is not known, then it is a good idea to get the amendment or product tested before applying to soils with high sodium content.



Practices such as using mouldboard ploughs on soils with sodic subsoils should be avoided because of the risk of bringing sodic subsoil material to the soil surface.

Bulk density

Bulk density is a measure of soil porosity and is the best indicator of compaction layers (e.g. plough pans) in the soil and soil structure.

What is bulk density?

Bulk density is the ratio of the weight of oven-dried soil (its mass) to its volume. Bulk density is influenced by the structure of the soil, how tightly packed the soil particles are and the size and number of air spaces within the soil. Soil texture will affect bulk density readings. Clay soils tend to have lower bulk densities than sandy soils because they have a greater number of pore spaces due to their smaller aggregate size.

Why is bulk density important?

Bulk density relates to the number of pores of various sizes in the soil. This is important for water and air movement through the soil and good root growth. If there are not enough soil pores then roots need to work harder to take up water and nutrients as well as to push through the soil. During compaction or aggregate breakdown larger pores are lost. Root development is severely retarded in these soils, leading to restricted root systems and an overall decrease in plant health and crop yield.

What does bulk density measure?

$$\text{Bulk density (BD)} = \frac{\text{Mass of oven-dried soil (g)}}{\text{Volume of soil (cm}^3\text{)}}$$

Bulk density is measured in g/cm³. A higher value means the soil has fewer spaces between the soil particles. High bulk density measurements indicate compaction, poor soil structure and restriction to root growth.

Soil porosity (%) can be calculated from bulk density as $100 \times (1 - \text{BD}/2.65)$ where 2.65 g/cm³ is assumed to be the absolute density of soil solids.

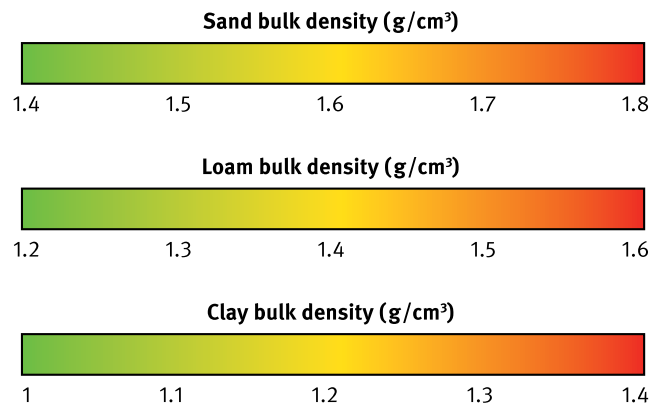





Figure 16. Guide to the interpretation of bulk density values for sand, loam and clay soils



How to measure bulk density

Bulk density is not measured by commercial laboratories. However, with the right equipment and procedure anyone can measure bulk density.

What you need	Steps to follow
<ul style="list-style-type: none"> • 7.5 cm diameter aluminium cylinder (length can vary, but about 10–12 cm works well) • rubber mallet • block of wood • long-bladed shovel or spade • paint scraper • sealable plastic bag • permanent marker.    	<ul style="list-style-type: none"> • A 7.5 cm (or 3") aluminium cylinder is used to determine the soil bulk density (for example use old aluminium irrigation pipe). Sharpen the edge on one end of the cylinder. This is the end that is driven into the ground. • Determine the volume of the cylinder— volume = length x 3.14 x (radius)². • Determine the weight of the cylinder. This can be written in permanent marker on the cylinder as this weight is needed later for calculating the amount of dry soil in the cylinder. • Carefully remove the surface vegetation from the sampling point. • Use the block of wood and a rubber mallet to drive the cylinder into the soil until its top edge is level with the soil surface. • Carefully dig up the cylinder. Trim the soil core level to the top and bottom of the cylinder with the scraper and scrape any soil from the outsides. • If there are big clods of soil that fall out of the cylinder it will give an underestimation of the soil bulk density. It is important to retain all the soil from within the cylinder. • Very carefully, put the cylinder and the entire soil core into a labelled plastic bag. • When you return from the field carefully take the cylinder of soil out of the plastic bag. The soil will still contain the same moisture it had in the field. This is referred to as the ‘wet soil’ – (including any loose soil). Determine the wet weight of the soil and the cylinder together. Record this weight on a recording sheet. • Place the cylinder with the soil core onto a metal tray with at least 2cm high edges (along with any soil that had dislodged from the cylinder), and then place in an oven to dry. Ideally, the soil should be allowed to dry for three days at 105 °C. • Once the soil is dry, determine the weight of the cylinder and the soil again. Subtract the weight of the cylinder from this measurement. This gives the dry weight of the soil, with all the water removed from the pore spaces. $\text{Bulk density (BD)} = \frac{\text{Mass of oven-dried soil (g)}}{\text{Volume of soil (cm}^3\text{)}}$

What practices change bulk density?

Tillage can have both a negative and positive effect on bulk density. Tillage itself is a tool to decrease bulk density, reduce compaction and increase soil aeration at least in the short term.

However, working soils that are wetter than their plastic limit will lead to compaction. Working soils when they are too dry or using aggressive tillage will break up natural aggregates and damage soil

structure. Any practices that cause a decrease in soil organic matter levels is also likely to impact on soil structure and hence soil porosity and aeration.

Reduced tillage can help preserve organic matter while crop rotations, green manure crops, and compost and other organic soil amendments will help increase organic matter. In permanent bed systems, bed renovation every few years can be a useful tool for decreasing bulk density and improving soil aeration (see ‘Tillage’ on p. 38).



Aggregate stability

What is aggregate stability?

Aggregate stability is an indicator of soil structure. It refers to how well soil particles hold together when wet or exposed to dispersive or deforming forces such as rainfall or tillage. The soil particles are naturally held together by organic glues to form irregular-shaped aggregates, and it is these aggregates that give soil its structure.

Aggregate stability is largely influenced by organic matter and biological activity in the soil.

Aggregates are formed by several processes:

- Fungal hyphae can entangle fine soil particles.
- Exudates from plant roots and the decomposition of organic matter can act as glues.
- The activity of soil fauna (e.g. earthworms and termites) contributes to stable aggregates.

Why is aggregate stability important?

A soil with good aggregate stability has good soil porosity, which favours water infiltration, good water-holding capacity, good tilth and adequate aeration for plant growth, nutrient recycling and root development. When soils with poor structural stability become wet, the aggregates disintegrate causing surface crusting. Surface crusting leads to increased run-off and an increased risk of erosion.



Figure 17. 20 g of sieved soil is wetted to determine its stability against the dispersal forces of water

What does aggregate stability measure?

Aggregate stability measures the ability of aggregates to withstand the disruptive forces of water and machinery and is expressed as a percentage of aggregated soil remaining after soaking in water.

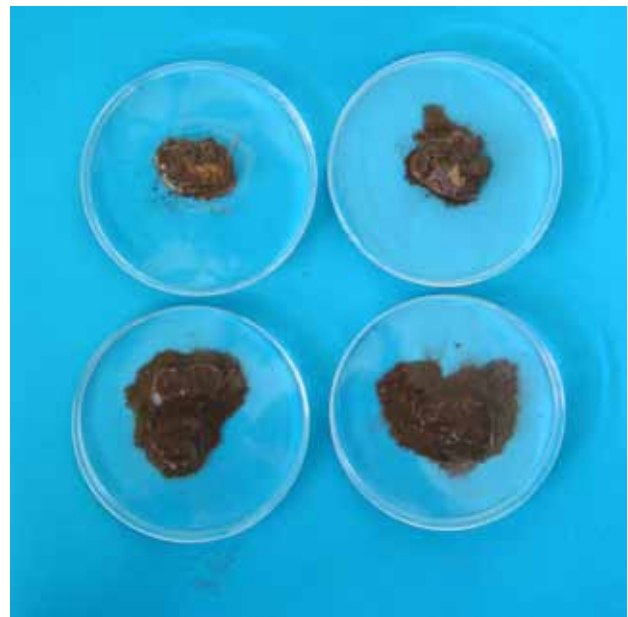

Figure 18. Low organic matter soil aggregates fall apart when wetted (bottom dishes) while those with high organic matter maintain their stability (top dishes)

How to measure aggregate stability

There are several methods for measuring the stability of soil aggregates. A simple method is:

- Pass some dry soil through a 4 mm and then a 2 mm sieve.
- Weigh a small bag made from 0.5 mm mosquito netting (see Figure 17). Record the weight. Take a 20 g sample of soil that is retained on the 2 mm sieve and place this into the bag.
- Gently lower and raise the soil bag in distilled or deionised water at around 30 dips per minute for two minutes.
- Place the bag and the remaining soil on a metal tray, dry in an oven at 40°C overnight and then weigh the bag and soil, including any loose soil on the tray. The weight of soil is total weight minus weight of the bag.
- Aggregate stability is then calculated as the percentage of soil remaining after washing as a proportion of the soil that was originally placed in the bag. The more stable the aggregates, the greater the amount of soil remaining.



Aggregate stability (%) =

$$\frac{\text{Dry weight of soil after washing} - \text{Weight of bag (g)}}{\text{Dry weight of soil before washing} - \text{Weight of bag (g)}}$$

This test is not appropriate for sandy soils. Sandy soils will generally not form aggregates because of the large size of the soil particles. However, aggregate stability is very important in loam and clay soils.

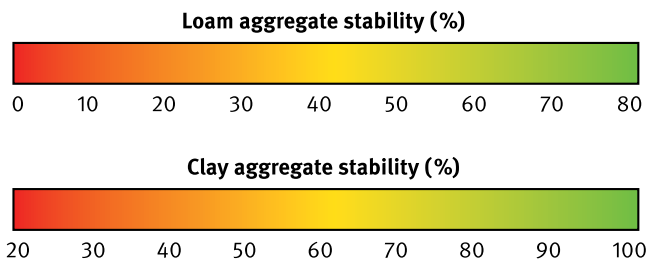

Figure 19. Guide to interpretation of aggregate stability values for loam and clay soils

What practices change aggregate stability?

Management practices such as minimum tillage, increasing soil organic matter and increasing biological activity can improve the soil's ability to resist forces that destroy aggregation.

Drop penetrometer to measure soil resistance

What is a drop penetrometer?

A penetrometer is any device designed to measure soil resistance. That is, the ease with which an object can be pushed or driven into the soil. Soil resistance will vary depending on soil conditions such as texture but particularly soil moisture. It takes less force to push a penetrometer into wet soils than dry soils. Therefore, penetrometer resistance readings are a relative measure of the soil conditions at that point in time.

It is possible to standardise penetrometer readings by either taking the measurements at a certain soil moisture content (e.g. two days after irrigation or rainfall) or by comparing two different practices on the same soil type that has received the same rainfall and irrigation.

Why is soil resistance important?

Resistance of the soil to penetration may be an indication of surface crusting or subsoil compaction. In soils that have a relatively high resistance to penetration, root growth may be severely restricted and drainage may be poor. Also, more power is required to cultivate soils resistant to penetration. This results in greater costs of production.

What does a drop penetrometer measure?

A drop penetrometer measures the soil resistance by dropping a known weight over a specific distance to force the penetrometer into the soil. It provides a consistent measure of resistance, and reduces the variability caused by operator error. Soil resistance is measured in kg/cm² and indicates the level of soil compaction.

Resistance measurements can be compared at two different areas in the same paddock, such as in wheel tracks and the row area. Also, the shape of the curve that joins the resistances readings at different soil depths may indicate subsoil compaction (Figure 22). Some increase in soil resistance with depth is expected but a sharp increase or a doubling of the resistance is usually an indicator of subsurface compaction.



Figure 20: Using a drop penetrometer in the field to measure soil resistance

How to measure soil resistance

Penetration resistance is measured by converting the number of drops it takes to push the penetrometer tip (of a given surface area) through 10 cm of soil with a known weight, falling over a known distance. This information is then converted to a resistance reading using the information below:

$$\text{Resistance (kg/cm}^2\text{)} = \frac{M^2 h n}{2(M + m) S Z}$$

Where:

M = weight of hammer (kg)

m = weight of penetrometer (kg)

h = height of hammer drop (m)

n = number of hammer drops

S = area of penetrometer tip (cm²)

Z = depth of penetration (cm)



Figure 21. Blueprint for constructing a drop penetrometer

Materials & specifications:

- 15.88 mm diam. 4140 steel shaft
 - 1 x 825 mm
 - 1 x 1145 mm
- Hammer blocks
 - 1 x 75 mm diam. x 58.85 mm length brite (2 kg)
 - 1 x 15/8" diam. x 58.85 mm length brite (0.5 kg)
- 39 mm diam. black shaft - 1 x 60 mm length
 - 1 x 40 mm length
- Total penetrometer weight (without hammer)
 - 3.8 kg
- 950 mm hammer drop

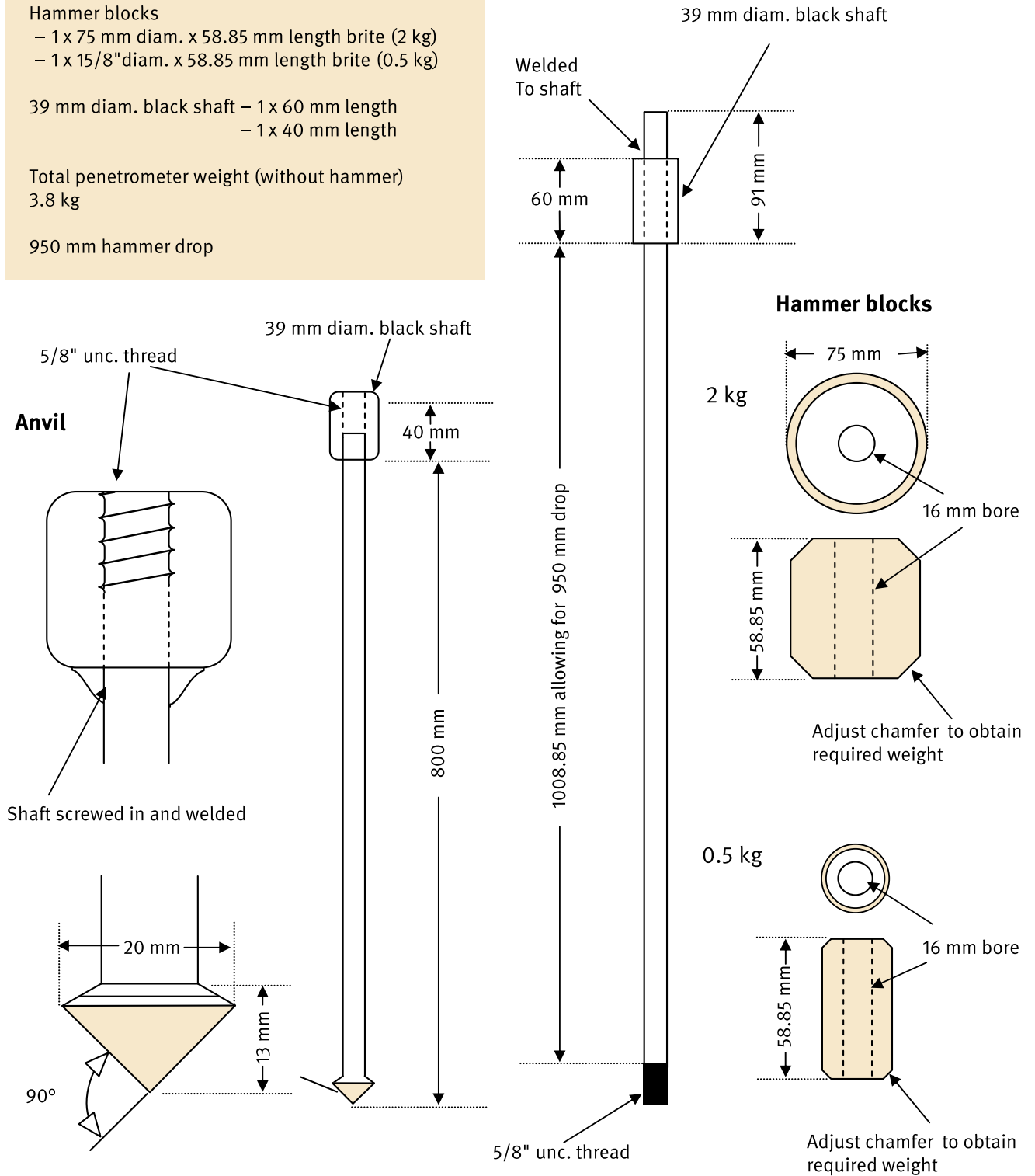



A drop penetrator can be easily constructed by an engineering firm using the ‘blueprint’ in Figure 21. Alternatively they can be purchased from some Australian distributors as a ‘dynamic cone penetrometer’.

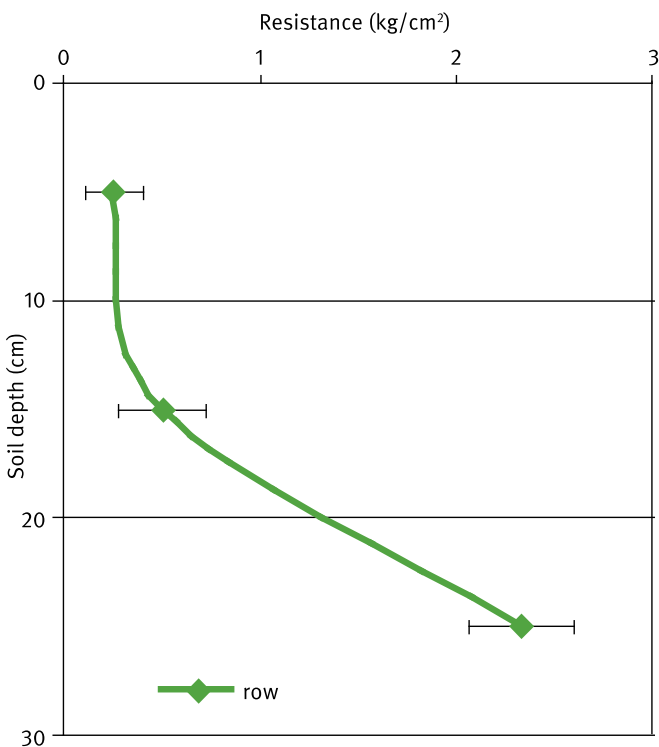
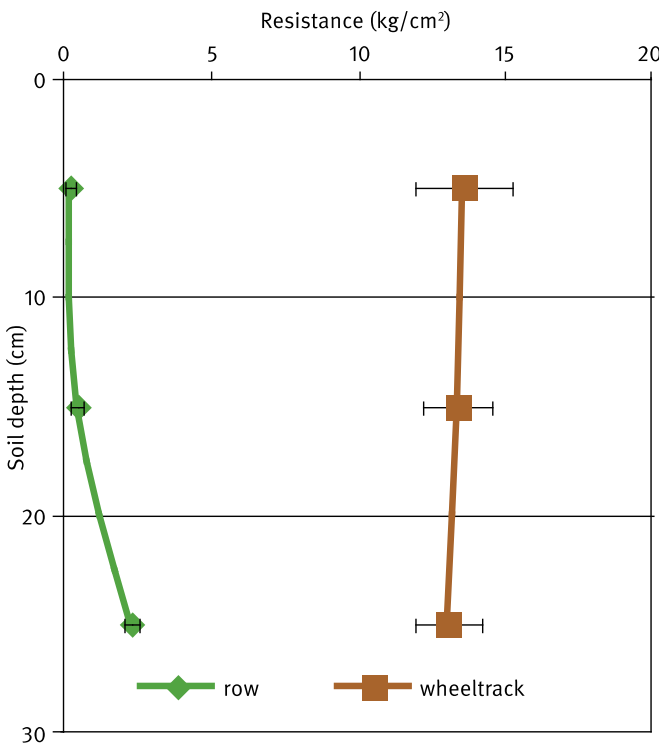

Figure 22. Soil resistance is greater in wheel tracks than row area down a soil profile to 30 cm (top graph). The shape of the resistance curve is important, a sharp increase in the resistance reading can show a subsurface compaction layer (bottom graph)

What practices change soil resistance?

Reduced machinery trafficking, deep tillage, minimum tillage, permanent beds and increased mulching are some practices that can minimise the risk of compaction. Alternating between crops with fibrous and tap roots can help break compacted soils by allowing the roots to push past soil particles and develop deep channels where old root systems once were.

Soil drop test

What is the drop test?

A soil drop test is a simple visual assessment of the soil structure. The test assesses how the soil breaks apart when dropped from a standard height. The soil can be rated as having poor, moderate or good soil structure.

Why is the drop test important?

Good soil structure regulates soil air and water. Soils with poor structure may have large, dense clods that make root penetration difficult. Soils that have no structure and produce a powder—often from over-tillage—may produce surface crusts.

What does a drop test measure?

The assessment of soil structure is based on the size and abundance of soil aggregates and clods when the soil is dropped. A soil with good soil structure will have an even distribution of friable fine aggregates. Soil with poor soil structure will have an abundance of large clods or they may shatter into a fine powder with no aggregate formation. A description of a rating system is given by Shepard (2000).



How to do the drop test

What you need	Steps to follow
<ul style="list-style-type: none"> • spade • plastic bucket • plastic sheet • camera. 	<ul style="list-style-type: none"> • The test is best done within a week after either rainfall or irrigation. • Remove a cube of topsoil with a spade. Aim for a cube with width and depth equal to the width of the spade blade. • Drop the soil cube once from the spade from about 1 m high (hip height) onto a firm base within a large plastic container. • Then pick up and drop individual larger clods a maximum of two more times. If clods break into smaller units, they do not need to be dropped again. • Place all the soil onto a plastic sheet to sort the soil in ascending order of aggregate size to obtain a size distribution (see photo). Using different size sieves can help to categorise the soil aggregates. • This distribution of aggregate size can be assessed, compared and photographed for future reference. Well-structured soil should break apart into fine aggregates, with few coarse clods and minimal fine powder.

What practices change a soil drop test?

To maintain soil structure it is important to minimise disturbance (e.g. tillage, trafficking), retain crop residues on the soil surface and maintain ground cover.

Measures of soil biology

Nematode diversity

This measurement is still under development in research laboratories and is not yet available through commercial laboratories. The measure has good potential to be an indicator of the activity of living organisms in the soil. The measure requires further validation to set sound thresholds.

What is a nematode?

Nematodes are unsegmented, worm-like organisms found in a wide range of environments and organisms, including seawater, freshwater, animals, plants and soils. Nematodes are the most abundant multi-cellular organism on the earth, and plant-feeding (parasitic) nematodes can cause a lot of damage to some agricultural crops.

In soils, nematodes inhabit water-filled pore spaces and can be classified into the following feeding groups:

- fungal feeders
- bacterial feeders
- plant-feeders
- predators and omnivores.

The mouth structures are used to differentiate species into their feeding groups. Other morphological details may be used to distinguish nematodes that feed on the same type of food substrates.



Figure 23. Soil nematodes can be useful indicators of soil health because of the many different types that can be found in the soil

What is nematode diversity?

Diversity refers to the proportion of different types of nematodes present in the soil. Nematode diversity is an indicator of the overall biological diversity in the soil.

Why is nematode diversity important?

Different types of soil-dwelling nematodes have a wide range of feeding levels. Some nematodes are parasitic (they feed on plant roots), others are beneficial (they feed on micro-organisms in the soil) and others are predatory (they feed on other nematodes).

The life strategies of different types of nematodes differ. Some are quick to reproduce and dominate the soil when conditions are favourable (e.g. following the addition of nutrients or organic matter). Others



are slow to reproduce and take a long time to reach peak numbers after soil disturbance such as tillage or the application of soil pesticides. Therefore, by knowing the life strategy and what the nematodes feed on we are able to infer the impact of management practices on soil biology.

Not all nematode species feed on plant roots. Some feed on bacteria, some on fungi and some on other nematode species. Soils with high nematode diversity tend to have greater resilience to disturbance and have been linked to the natural suppression of plant diseases.

Nematodes occupy a central part of the soil food web. Their numbers do not fluctuate as quickly as fungi or bacteria, but they are still relatively quick to respond to changes in the soil environment. They are numerous in the soil, with around 50 nematodes present in each gram of topsoil.

Nematodes are relatively easy to extract from the soil but require a microscope and specialist training to be able to identify the different types.

What does nematode diversity measure?

By measuring the diversity of nematode types in soil we have information on how complex the soil food web is. Soils with a low nematode diversity have a simple food web, which has little biological buffering. Therefore, if plant parasitic organisms become established they are able to dominate the soil food web, because there will be very few predators or parasites to check their growth.

A greater nematode diversity in the soil also indicates greater nutrient recycling of complex substrates such as organic matter. Because organic matter is made up of a range of different compounds, it is broken down by a range of different organisms—including different nematode types.

How is nematode diversity measured?

Nematodes are removed from a soil sample using water. The number and evenness of different nematode species removed from the sample is then determined by microscopic examination. Nematode diversity is calculated using the Shannon–Weiner index of diversity.

If a lot of different nematode species are present, in roughly equal proportions, the diversity index will be high. However, if the soil nematode community has a high proportion of an individual species, the soil will have a low diversity index.

What practices change nematode diversity?

Nematode diversity will change with changes in soil conditions. Practices that increase nematode diversity include:

- increasing the diversity of plants growing on the soil surface
- rotation cropping
- avoiding bare fallows
- adding organic matter
- reducing tillage and soil disturbance
- reducing use of soil applied pesticides
- reducing fertiliser application.

Some soils (such as sandy soils) tend to have a lower nematode diversity. More intense soil use usually results in a lower diversity.